

## ADAPTOR FOR DRILL CHUCKS (JACOBS / DIN 238)

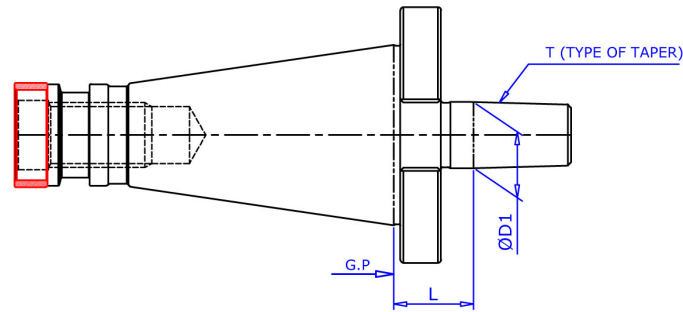

Taper Angle AT3 Class

Concentricity of MOUNTING taper is within 0.005mm.

DRG NO.	TOOL SHANK	T	L	Ø D1
ISO 30 B12	ISO 30	B.12	15.0	12.06
ISO 30 B16	ISO 30	B.16	15.0	15.73
ISO 40 B12	ISO 40	B.12	17.0	12.06
ISO 40 B16	ISO 40	B.16	17.0	15.73
ISO 40 B18	ISO 40	B.18	17.0	17.78
ISO 50 B16	ISO 50	B.16	20.0	15.73
ISO 50 B18	ISO 50	B.18	20.0	17.78
ISO 30 J2	ISO 30	J.2	15.0	14.19
ISO 30 J3	ISO 30	J.3	17.0	20.59
ISO 30 J6	ISO 30	J.6	15.0	17.17
ISO 40 J1	ISO 40	J.1	22.0	9.75
ISO 40 J2	ISO 40	J.2	17.0	14.19
ISO 40 J33	ISO 40	J.33	17.0	15.85
ISO 50 J2	ISO 50	J.2	24.0	14.19
ISO 50 J3	ISO 50	J.3	25.0	20.59
ISO 50 J6	ISO 50	J.6	20.0	17.17

Ordering Example :- ISO40 B16 - 2 Nos.